

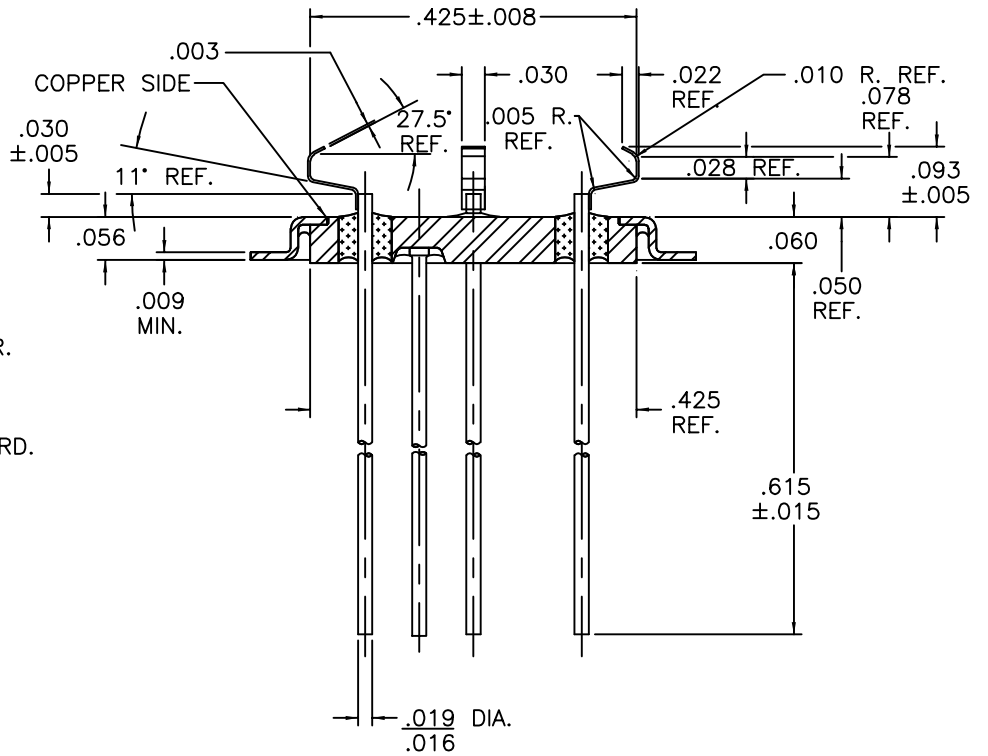

REV	DESCRIPTION OF REVISION	E.C.N.	BY	APPROVED	DATE
A	MADE .022 A REF. DIM., .076±.005 A REF. AND .050±.005 A REF.		E.T.W.	A.J.A.	08-08-02
B	FILE NO.: WAS EB00058.SKD		E.T.W.	A.B.	02-22-05

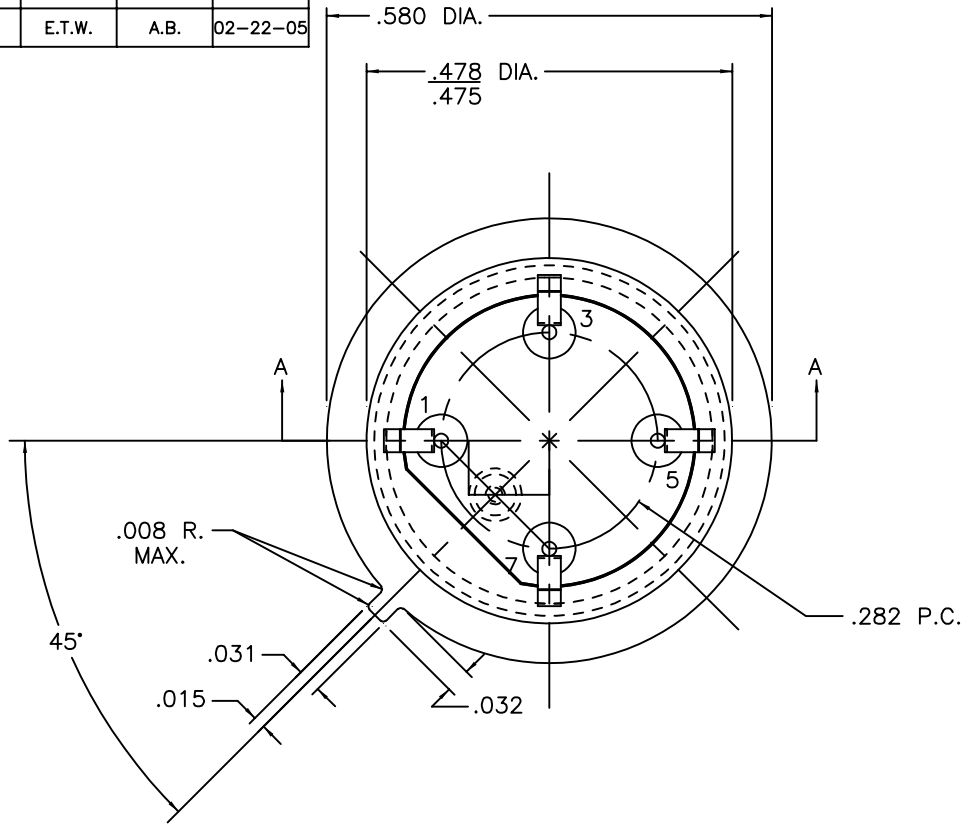

NOTE:
POST HEIGHT IS SPECIFIED OFF THE HIGHEST POINT ON THE POST SIDE.

MATERIAL:
EYELET - 1010 C.R.S. OR EQUAL.
FLANGE - 30/70 COPPER CLAD KOVAR.
GLASS - 7052 OR EQUAL, OPAQUE.
LEADS - ASTM F-15 ALLOY, KOVAR.
BRAZE - AG. CU. INDIUM ALLOY.
MOUNT - 200 NICKEL ALLOY, 1/2 HARD.

PLATING:
1. ELECTROLESS NICKEL FINAL PLATE OF 100 MICROINCHES MINIMUM.
2. OPTIONAL SOLDER COAT ON LEADS ONLY PER MIL-STD QQ-S-571-D TIN LEAD ALLOY.
3. OPTIONAL GOLD FLASH .99999 PURE 24 KARAT GOLD UP TO A MAX. OF 8 MICROINCHES OVER THE ELECTROLESS NICKEL FINAL PLATE.

DRAWN BY: E.T.W. 06-25-02		MATERIAL: SEE ABOVE		TOLERANCING PER ANSI Y14.5 .X ±.005 .XXX ±.005 .XX ±.005 ANG ±5° UNLESS OTHERWISE SPECIFIED		 Legacy Technologies Inc. 6700 W. 47th TERR. MISSION, KS. 66203 TEL: 913-432-2487 FAX: 913-432-0570	
CHECKED BY: A.B. 06-25-02		APP. SPECS	SUPERSEDES	NEXT ASSY LP-T08-.282 P.C.			PART NUMBER: LP-T08-017B-CMN330F
APPROVED BY: A.J.A. 06-25-02		TITLE: HC-37/U WIDE FLANGE LOW PROFILE				SCALE: 4:1	FINISH: UNLESS OTHERWISE SPECIFIED
				FILE: HM00009		PAGE 1 OF 1	